

## 前控制界面模块 (FCIM)

专用工具 / 通用设备

内饰拆卸器

拆卸

注意： 此过程中的拆除步骤可能包含安装步骤的详细信息。

1. 注意： 如果正在安装新模块，有必要在拆卸模块之前将模块配置信息上传到扫描工具。安装后该信息必须下载到新模块上。

使用诊断扫描工具，为PMI 过程 FCIM按照屏幕上的说明。

2. 通用设备： 内饰拆卸器

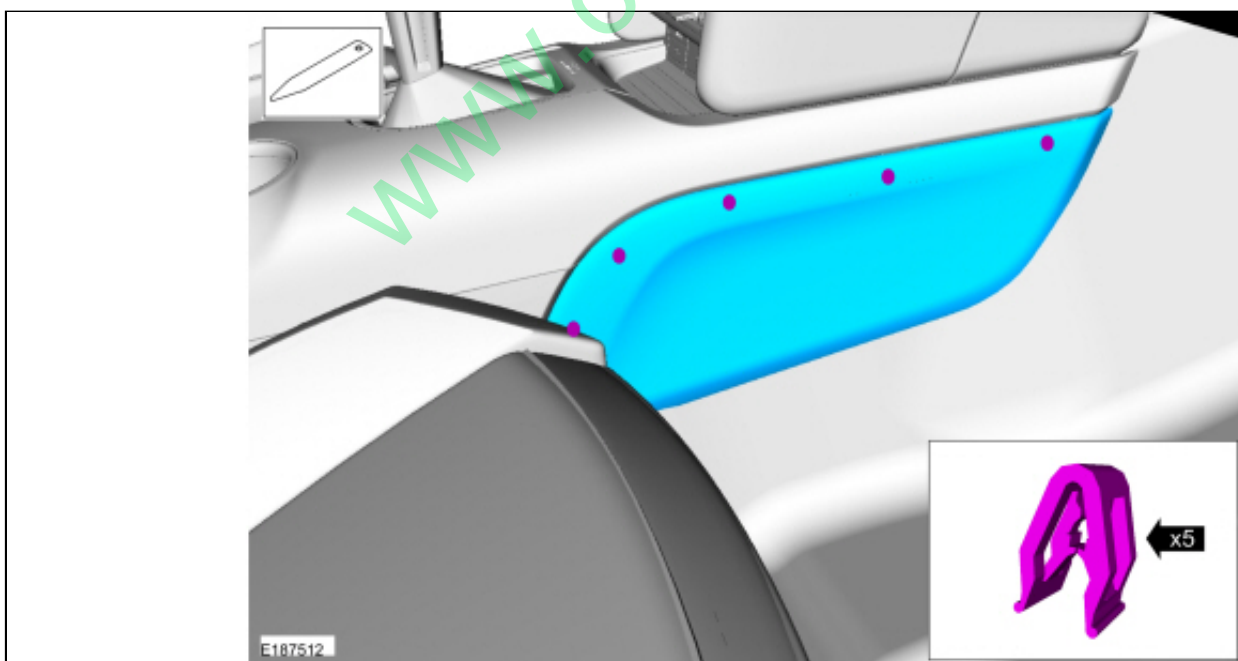

[Worksh  
Manual  
Graphi  
Traini](#)

[Click  
here  
to  
learn  
about  
symbol  
color  
coding  
and  
icons  
used  
in  
this  
manual](#)

3. 通用设备： 内饰拆卸器

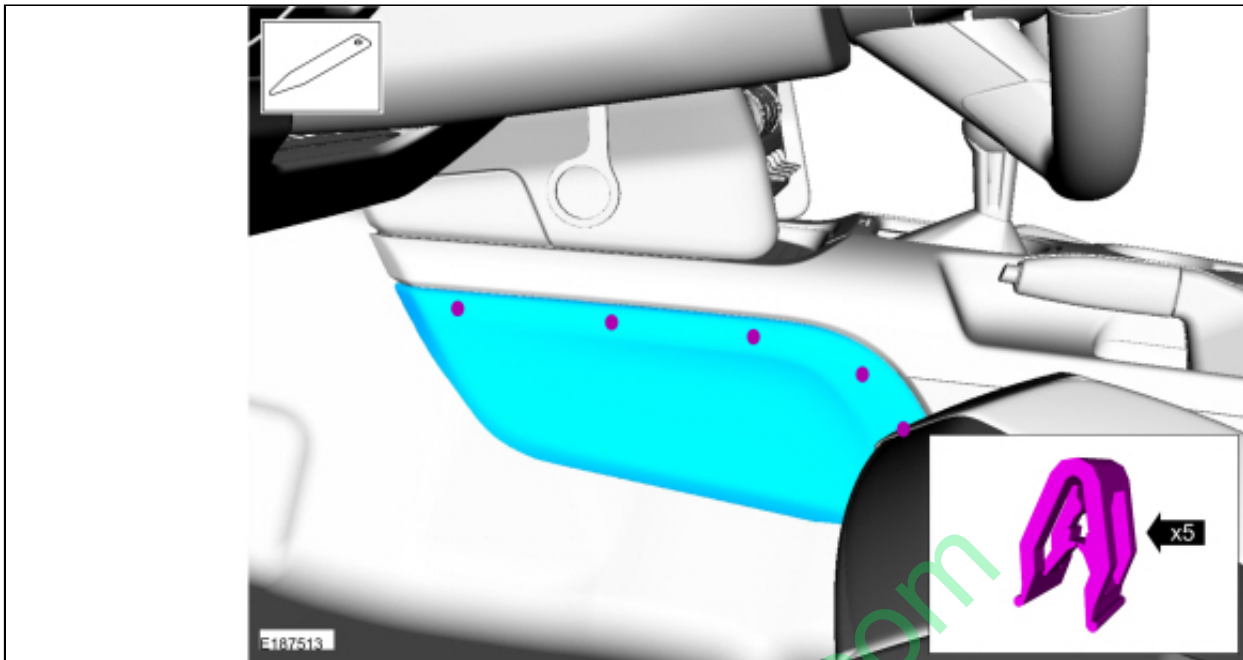



Click here to learn about symbol color coding and icons used in this manual

4.

www.car60.com

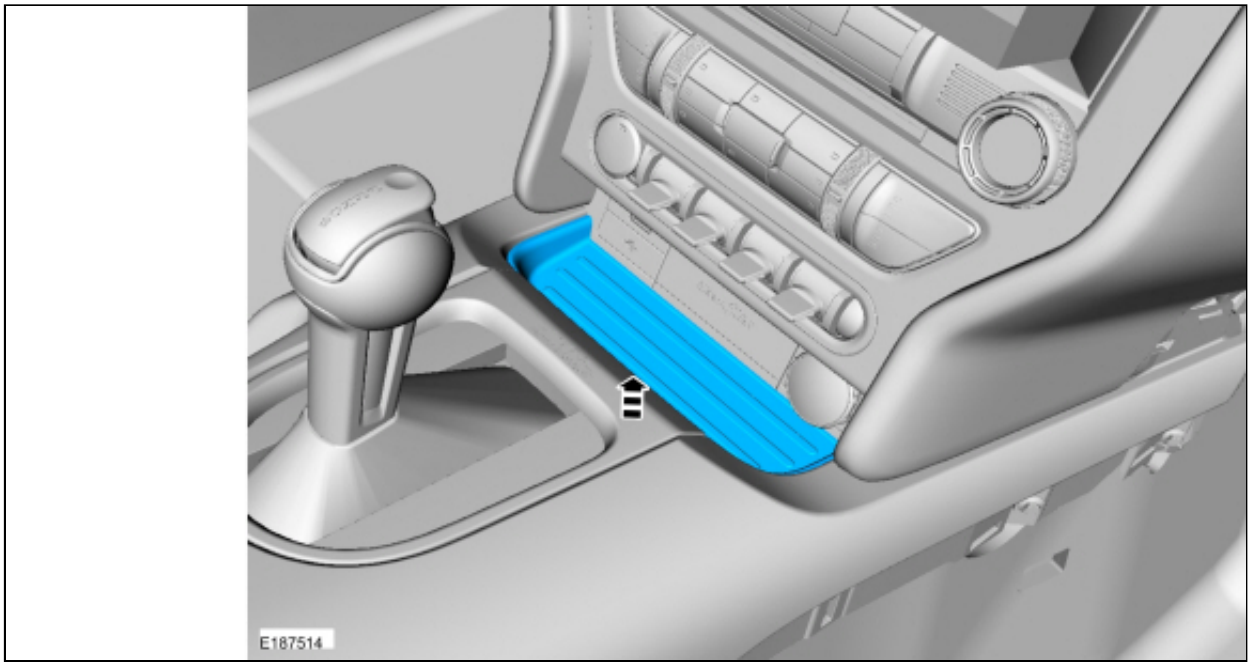
|  |
|--|
|  |
|  |
|  |
|  |
|  |
|  |



 [Click here to learn about symbol color coding and icons used in this manual](#)

5.

[www.car60.com](http://www.car60.com)

 [Worksh Manual Graphi Traini](#)

|  |
|--|
|  |
|  |
|  |
|  |
|  |
|  |

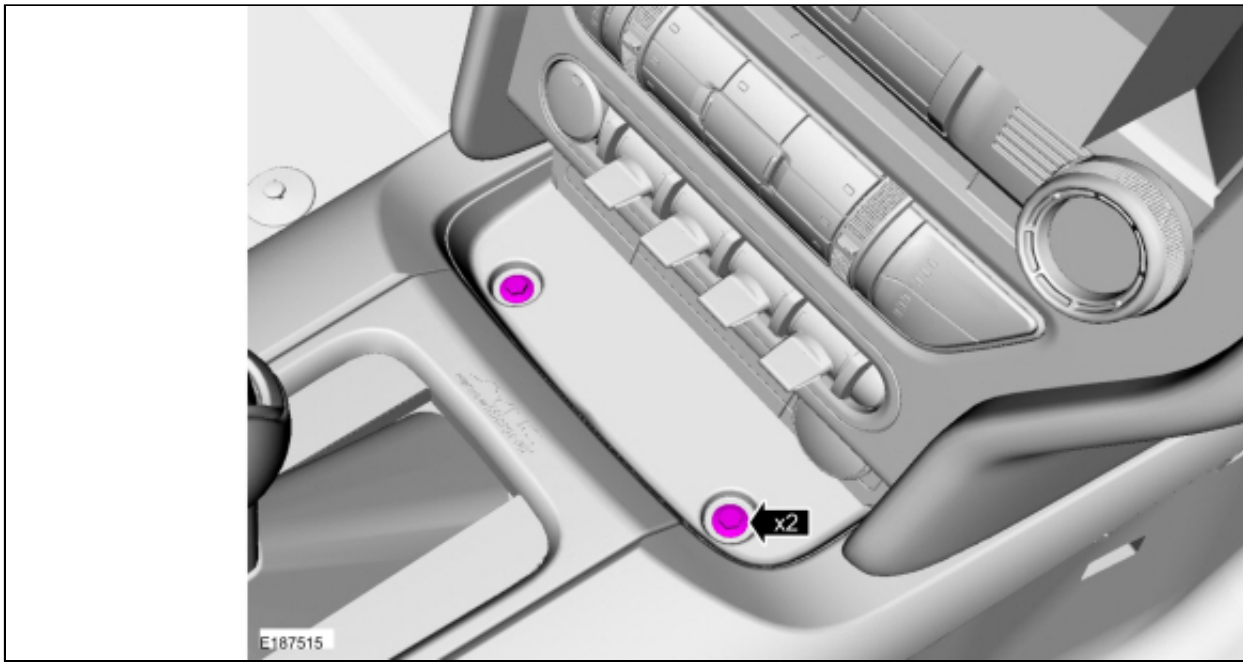

[Click here to learn about symbol color coding and icons used in this manual](#)

6. 注意： 图中所示为自动变速器，手动变速器与之类似。

通用设备：内饰拆卸器

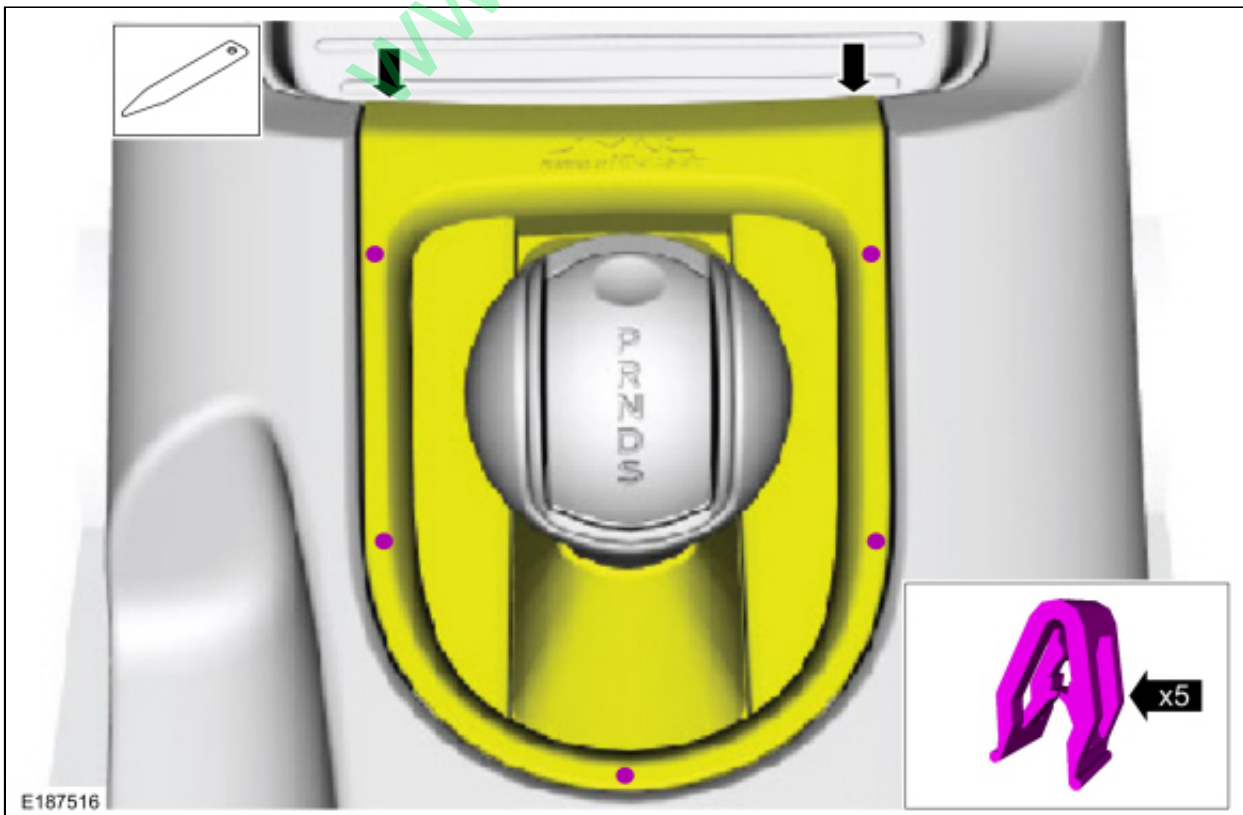

[Worksh Manual Graphi Traini](#)

|  |
|--|
|  |
|  |
|  |
|  |
|  |
|  |

E187516

 [Click here to learn about symbol color coding and icons used in this manual](#)

•

www.car60.com



 [Worksh Manual Graphi Traini](#)

|  |
|--|
|  |
|  |
|  |
|  |
|  |
|  |

 [Click here to learn about symbol color coding and icons used in this manual](#)

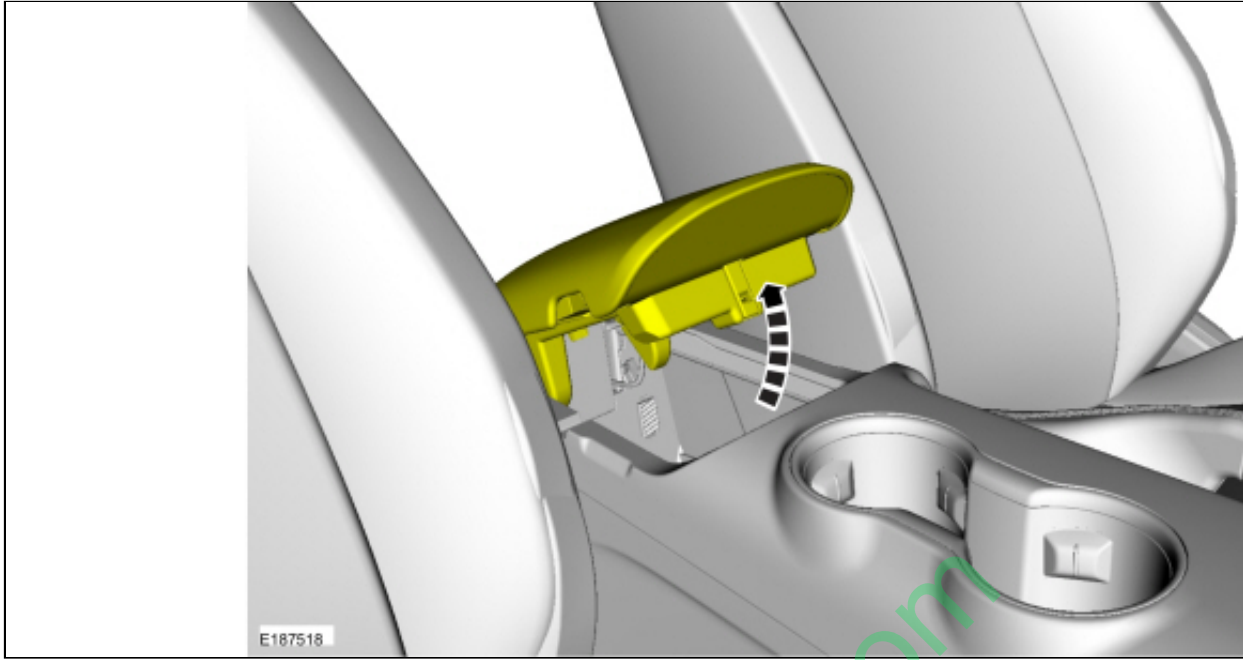

|  |
|--|
|  |
|  |
|  |
|  |
|  |
|  |

[Click here to learn about symbol color coding and icons used in this manual](#)

9. 扭矩: 2 Nm

www.car60.com

|  |
|--|
|  |
|  |
|  |
|  |
|  |
|  |

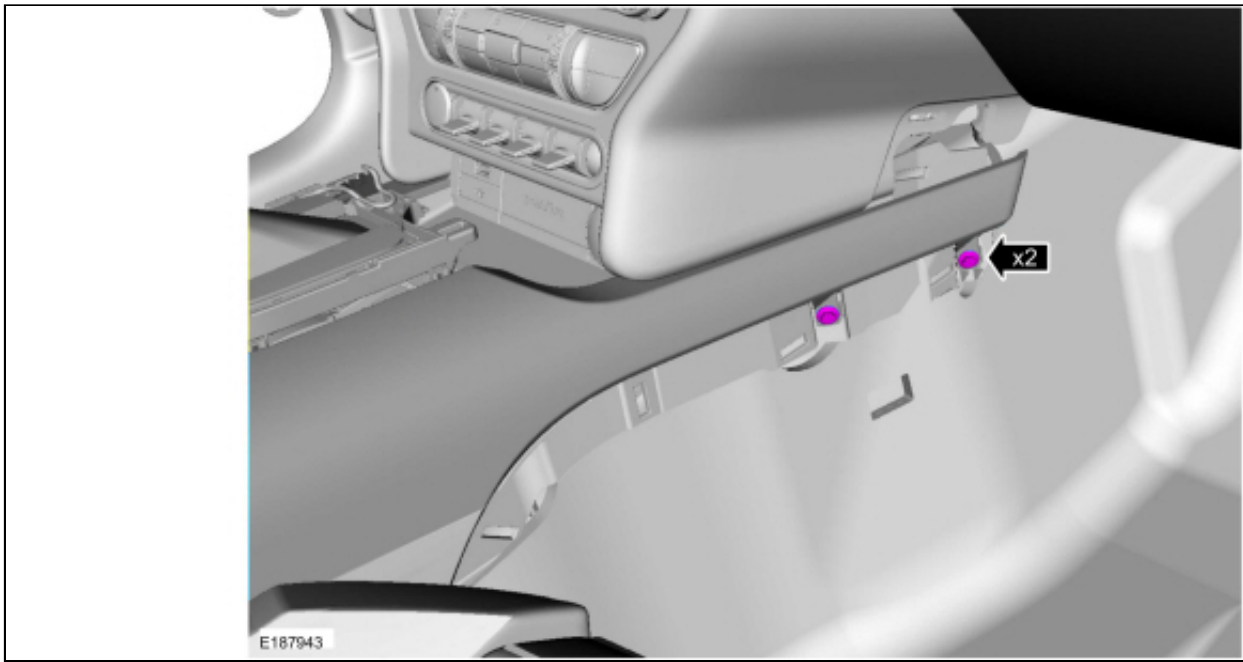

 [Click here to learn about symbol color coding and icons used in this manual](#)

10. 扭矩：2 Nm

www.car60.com

 [Worksh Manual Graphi Traini](#)

|  |
|--|
|  |
|  |
|  |
|  |
|  |
|  |

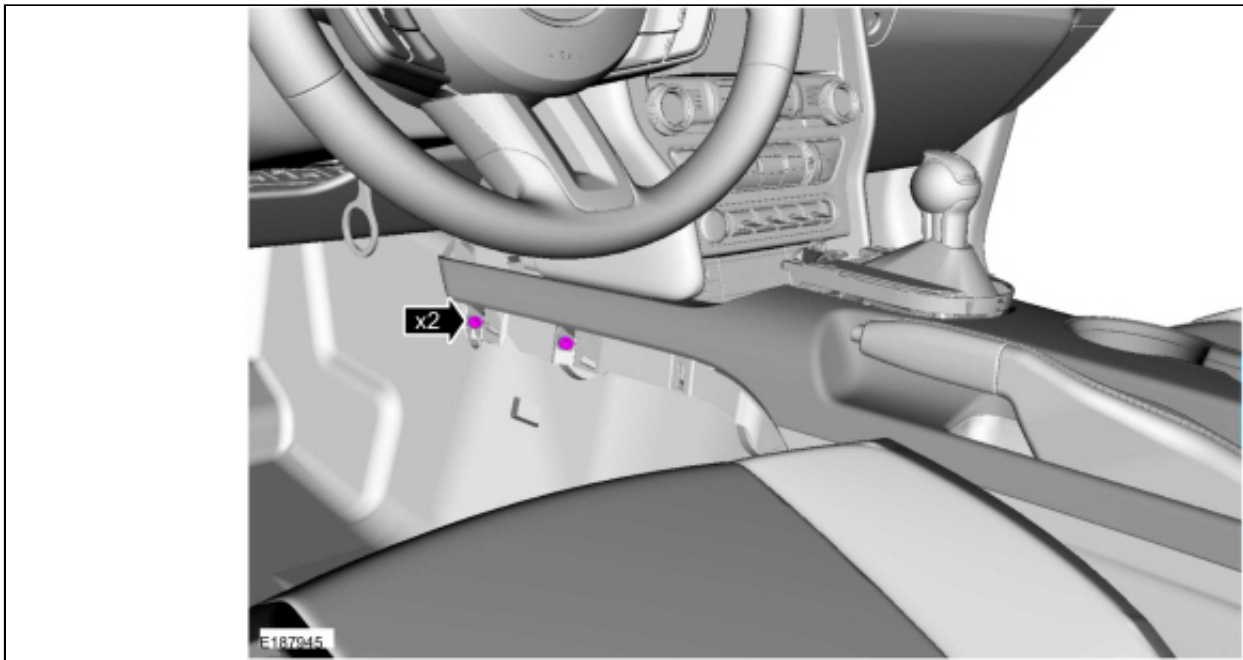

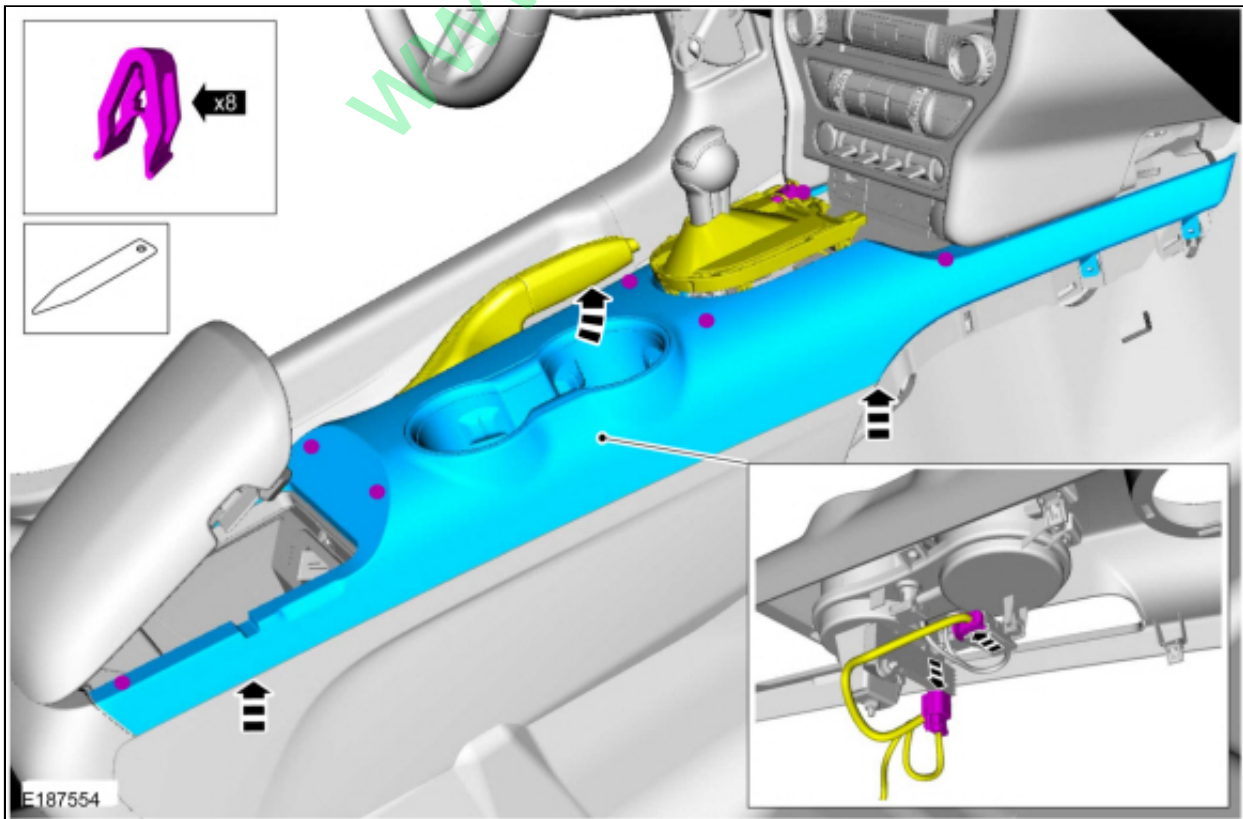

[Click here to learn about symbol color coding and icons used in this manual](#)

[www.car60.com](http://www.car60.com)





[Worksh Manual Graphi Traini](#)

|  |
|--|
|  |
|  |
|  |
|  |
|  |
|  |

 [Click here to learn about symbol color coding and icons used in this manual](#)

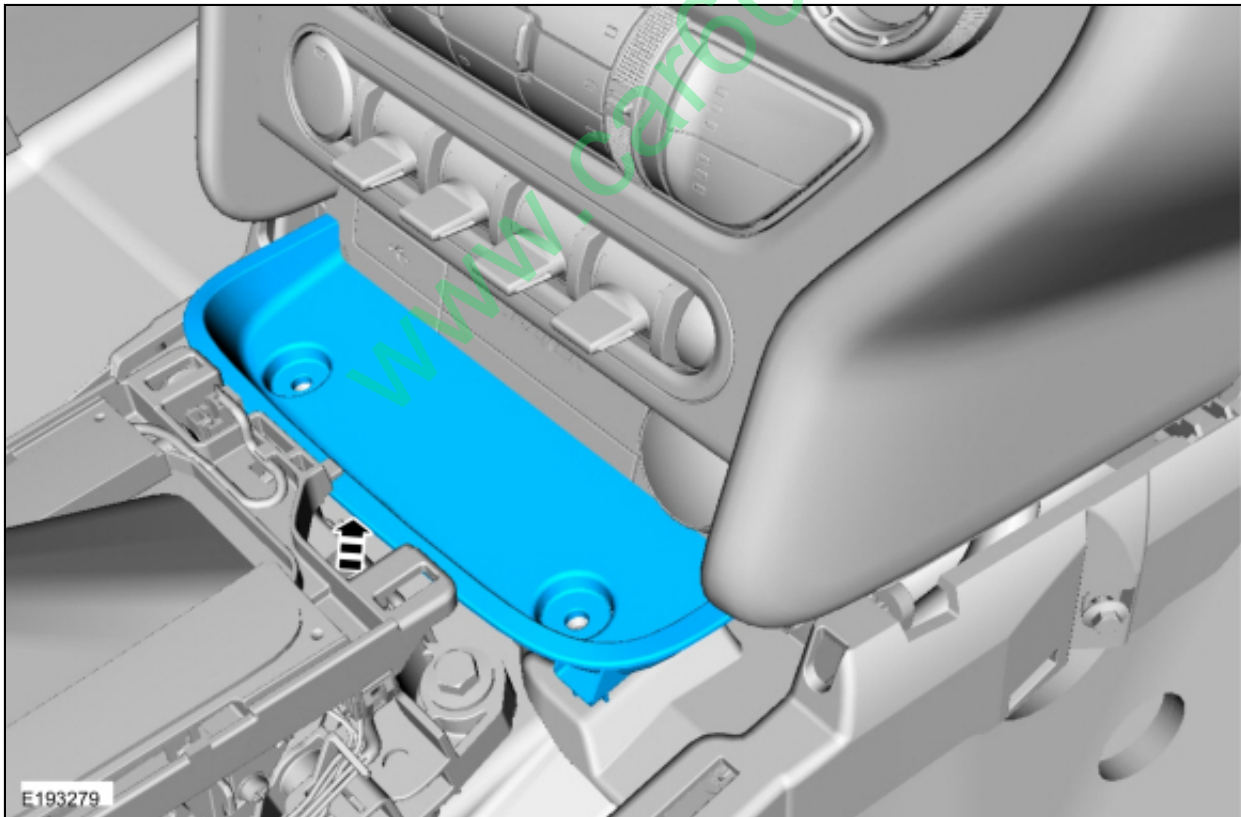
12.



 [Worksh Manual Graphi Traini](#)

|  |
|--|
|  |
|  |
|  |
|  |
|  |
|  |

 [Click here to learn about symbol color coding and icons used in this manual](#)

13. 拆卸仪表板中心面板。  
参阅：[仪表板中央罩板](#) (501-12 仪表盘和中控台，拆卸和安装)。

14. 通用设备：内饰拆卸器

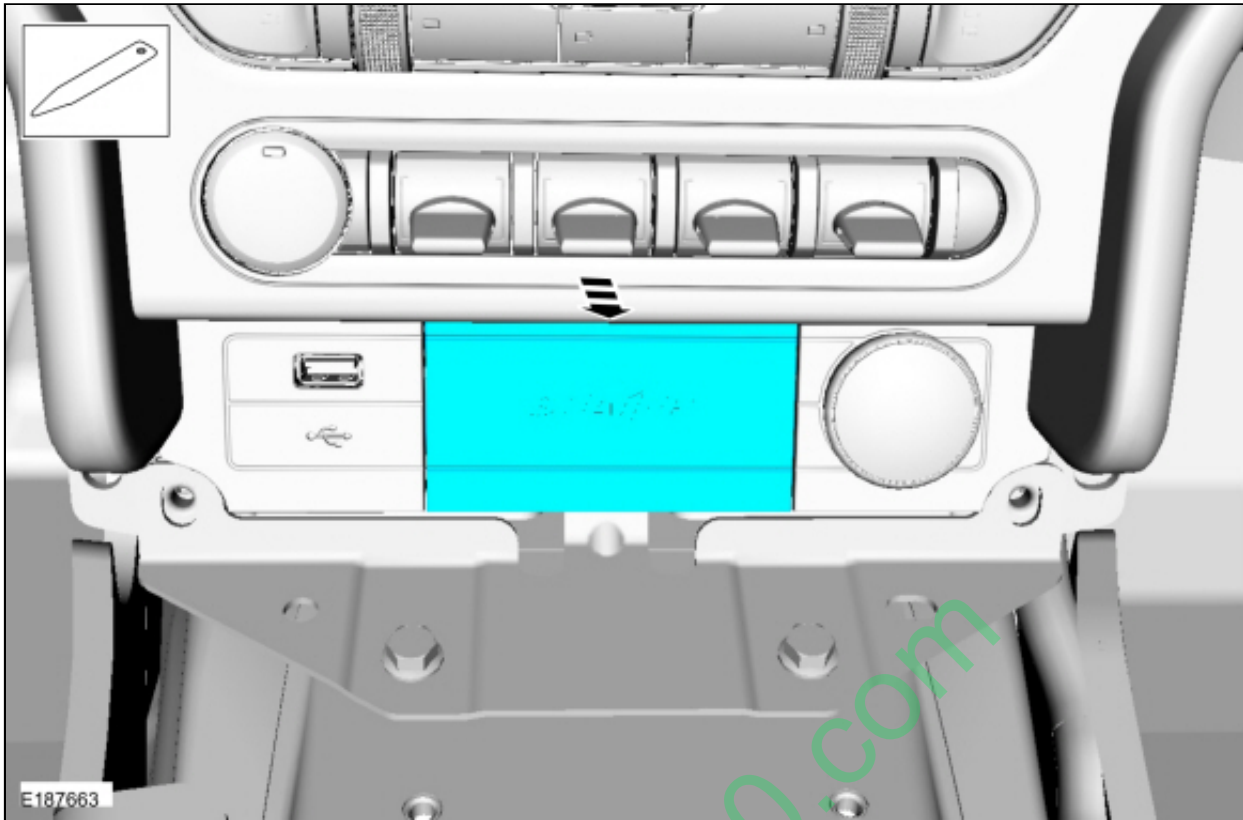

Click here to learn about symbol color coding and icons used in this manual

- 扭矩：2,5 Nm

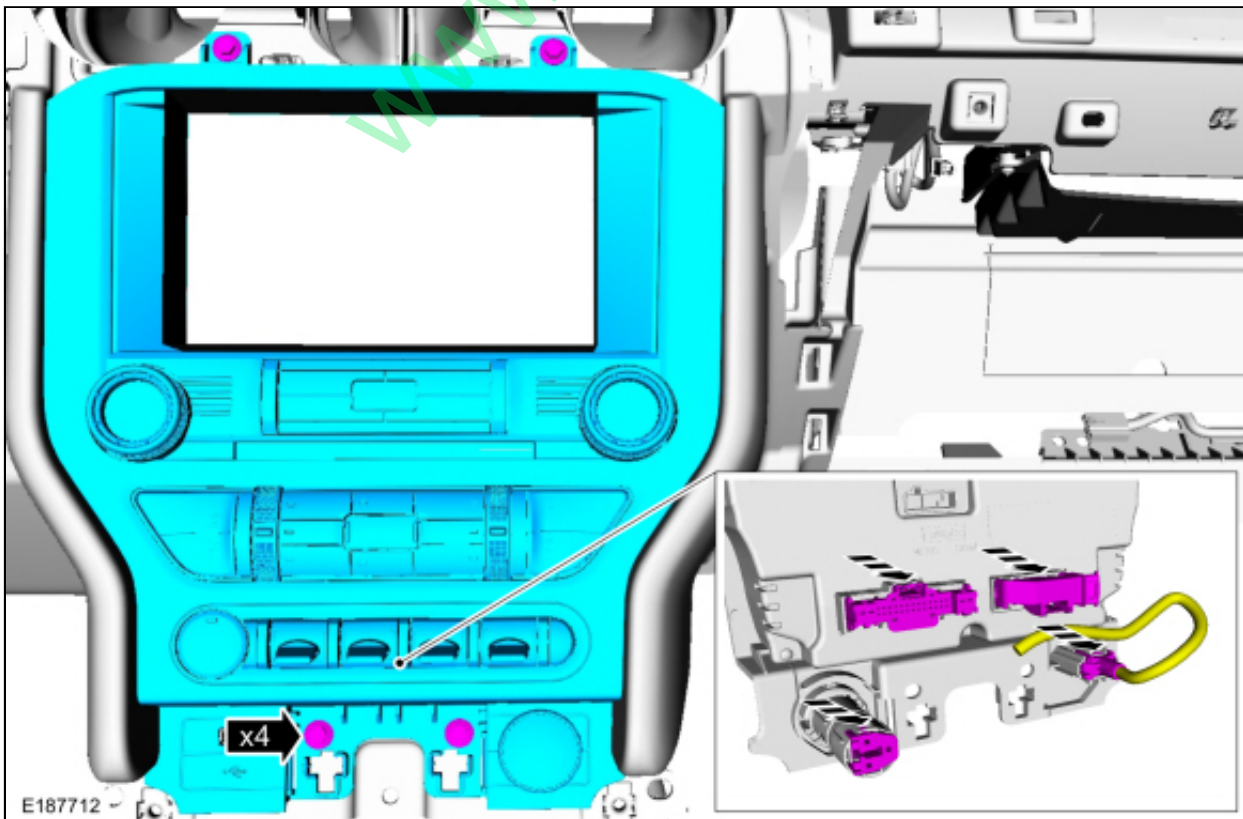

 [Click here to learn about symbol color coding and icons used in this manual](#)

## 安装

1. 零件按照拆除相反顺序进行安装。
2. 注意： 仅在更换部件时才需执行该步骤。

使用扫描工具，完成PMI程序 FCIM依照屏幕显示指示。

[www.car60.com](http://www.car60.com)